

HYPERION™

A Meech Innovation

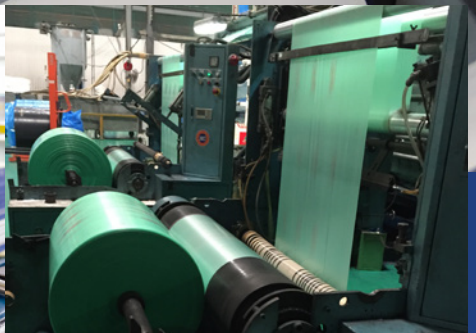

Static Control

Advanced 24V Technology



All about Meech

Established in 1907, Meech International is one of the world's leading manufacturers of static control, compressed air technology and web cleaning systems, both contact and non-contact.

The company has its headquarters in Oxfordshire (UK), with subsidiaries in the USA, Belgium and China, and offices in Hungary and India. These offices are backed up by a distribution network of more than 65 distributors in over 50 countries. Meech products are used in a vast range of industries including:

Aerospace
Automotive
Beverage
Converting
Food

Medical
Packaging
Pharmaceutical
Plastics
Printing

Meech has specialised in industrial electrostatic control for over 50 years. This experience has led to R&D that matches changing customer needs. Meech pioneered the industrial use of pulsed DC technology for static control and now has

thousands of systems installed in the plastics, converting, printing and packaging industries.

Static electricity is most commonly caused by friction, pressure or separation, with examples ranging from the unwinding of plastic film to everyday shocks from cars and door knobs.

Unchecked, static electricity can cause productivity, quality and safety problems throughout industry. Electrostatic attraction or repulsion generates dust contamination and product misbehaviour and an electrostatic discharge can shock operators, start fires and destroy electronic components.

Meech provides solutions to control static in virtually every production situation. The product range includes ionising bars, blowers, guns and nozzles, as well as ionising air curtains, power supplies and test & measuring equipment.

We've got the world covered

Wherever you are in the world you'll find Meech hard at work, providing a wide range of businesses with specialist expertise. From the headquarters and technical centre in the UK, our manufacturing subsidiary in the USA to the sales and marketing offices in Belgium, Hungary, China and India we've got the world covered. Our global network of distributors are carefully selected, fully trained and on call to provide in-depth technical support – wherever you're based.

Outstanding quality as standard

Quality is at the heart of every Meech system. We always work to the highest possible quality standards in everything we do: manufacturing, customer support and technical know-how. Our quality management system is certified by BSI to ISO9001. Products manufactured by Meech are also appropriately certified to international standards which include CENELEC EN 60950, UL/CSA (CUL) and CE. We also hold ATEX and UL“EX” approvals for use in hazardous environments. So, you can be sure you've chosen a solution and a company that will meet your own exacting standards.

All the experience you need

Meech has been at the forefront of innovation within the industry, earning a worldwide reputation for consistently designing, manufacturing and marketing products that offer unparalleled performance and technical superiority. This experience and reputation has helped grow the global user list which now includes companies like: 3M, Amcor, Avery Denison, BP, Bruckner Group, Ford, GlaxoSmithKline, Honda, Nestle, Nissan, Procter&Gamble, RPC Group and Tetra Pak

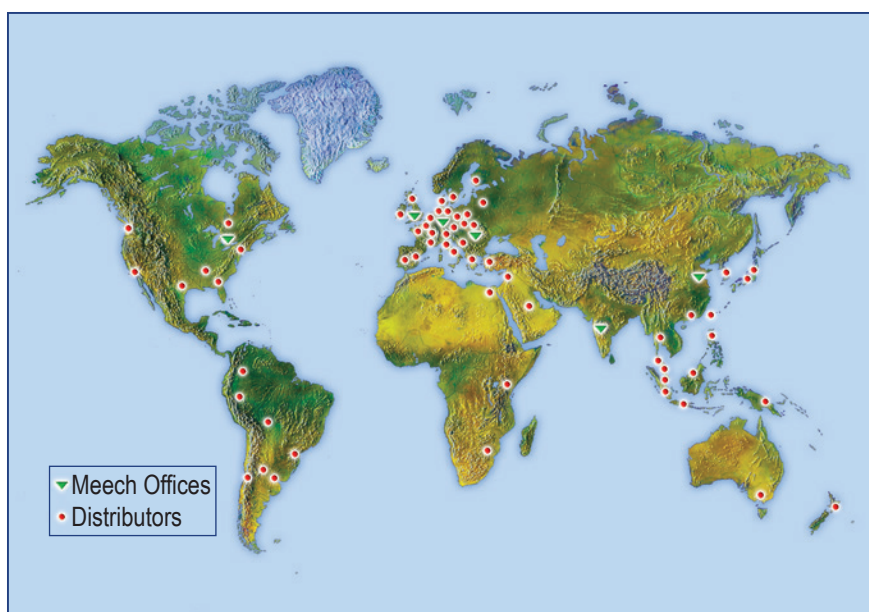

“Over the past nine months the static bars have proven to be more than efficient, so I can say we've been very satisfied with both the quality of the equipment and the service provided. We're confident that this installation will only benefit further the relationship between RPC and Meech.”

Technical and Development Manager, RPC

“We are very pleased with the results obtained. We managed to solve the problem existing in our production plant quickly; the feedback system manufactured by Meech guarantees the smooth running of the whole production process, and the products leaving our factory are of the world's highest quality”

Process Engineer, 3M

HYPERION™

A Meech Innovation

The Hyperion range of ionising bars and power supplies are the latest, revolutionary, industrial static control products offered by Meech. Developed by our engineers in conjunction with distributors and end users, the Hyperion range offers new levels of technical superiority for industrial static control. The range has been engineered to include a number of key characteristics such as Ion Current Monitoring (ICM) technology, clean pin alert and adjustable output voltage, frequency and balance.

Hyperion Bars

In the past the majority of ionising systems have required a 110/220V AC mains input to the power supply and then high voltage cabling to the ioniser. However, over time demand for 24V DC powered devices has increased significantly.

Meech has unrivalled knowledge of industrial pulsed DC

systems. Historically used for mid to long range applications, pulsed DC ionisation is powerful and flexible, making it ideal for today's modern fast moving equipment.

There is also a growing demand for compact ionisers to fit into small spaces. Typically, this has required AC ionisers. These need to be fitted close to the application and offer little flexibility or control.

In answer to these two demands Meech has developed the Hyperion range. Hyperion bars are designed to provide all the power, flexibility and features of a pulsed DC ionising bar combined with the compact dimensions and performance of an AC ionising bar.

There are currently 3 bars in the range, making Meech one of the only manufacturers to provide dedicated pulsed DC products for short, mid and long range ionisation. A comparison of the decay time vs operating distance for the bars can be seen below.

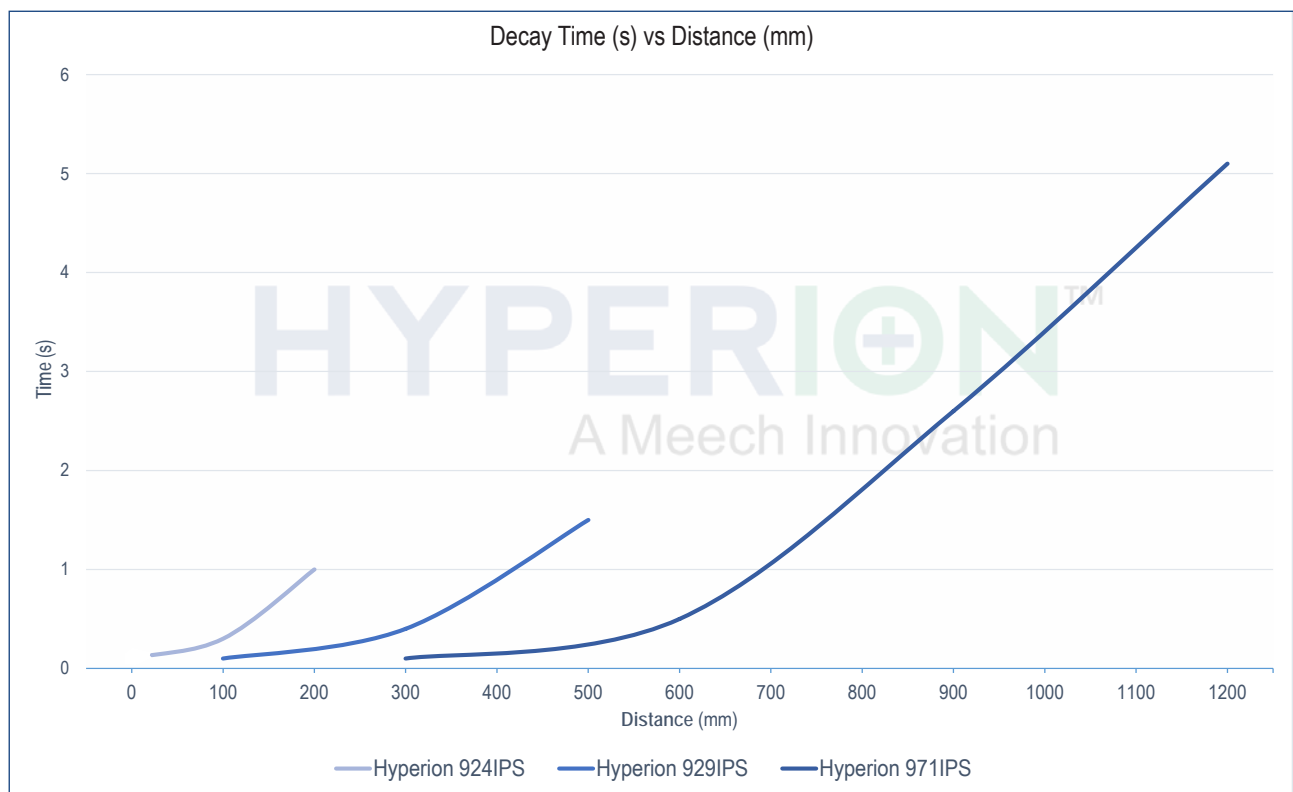

Hyperion Bar Feature Comparison

FEATURE	924IPS	929IPS	971IPS
Optimum Working Distance	20-200mm	100-500mm	300-900mm (1200mm with air boost)
Dimensions (W x H)	22mm x 32mm	26mm x 43mm	63mm x 70mm
Maximum Length	3960mm	2965mm	3950mm
Weight (per meter)	0.5kg	0.9kg	1.2kg
Construction	ABS Plastic FR	PVC/ABS FR	ABS Plastic FR
Mounting	'T' Slot with M4 x 20mm studs		
Shockless Titanium Emitters	✓		
Replaceable Emitter Pins	x	x	✓
Low Voltage Wiring	24V DC (21-27V DC)		
Output Voltage	4 to 7.5kV pulsed DC Adjustable	+/- 10kV pulsed DC	+/- 15kV pulsed DC
Adjustable Frequency	1Hz to 20Hz		
Adjustable Balance	80:20 To 20:80 Pos:Neg		
Clean Pin Alert	✓		
Integrated Power Supply (IPS)	✓		
Environmental Protection	IP66	IP66	IP64 or IP65
Output Signal	✓		
Divider	✓		
Air Assist available	x	x	Integrated

Hyperion Power Supplies

One restriction with AC ionisers has always been the requirement for a 110/220V AC mains supply.

The Hyperion range of power units bring AC ionisers up to date. Powered by 24V DC, now found on most machinery, they produce an adjustable output of up to 7kV AC. The electronic circuitry of the Hyperion 906 and 907 drives the ionisers more efficiently than traditional AC transformers. The benefit of this, is that the transformers are smaller and lighter.

The Hyperion 906 provides AC power for any Meech AC ioniser. The Hyperion 907 has additional features over the 906 including a clean pin alert and adjustable balance.

"The Meech systems now enable us to run our rewinding machines at twice the previous speed and have eliminated potential quality problems. Time is also saved with the Feedback automatic control system and operators are no longer concerned about the possibility of shocks due to static built up. Everyone from the management to the machine operators are delighted with the results."
*Production Manager,
Technibond*

"We were very impressed with the level of technical information that we received from Meech to ensure optimum operation of the equipment."
*Design Engineer,
Autobond*

Hyperion 924IPS

Short Range DC Ionising Bar



The Hyperion 924IPS is a short range pulsed DC ionising bar. It is powered by 24V DC and it is the most compact pulsed DC bar available on the market. This makes it the first 24V DC powered bar to be suitable for installation in positions that would normally require a traditional AC bar.

As with other Hyperion products, the 924IPS features Meech's Ion Current Monitoring (ICM) technology, this ensures performance is maintained with local and remote alerts when the bar needs cleaning.

Fully BarMaster compatible, the performance can be adjusted to suit particularly difficult applications. The 924IPS is the first Hyperion bar to have adjustable output voltage, frequency and balance. These features will help optimise the 924IPS for specific applications, including very sensitive applications such as RFID.

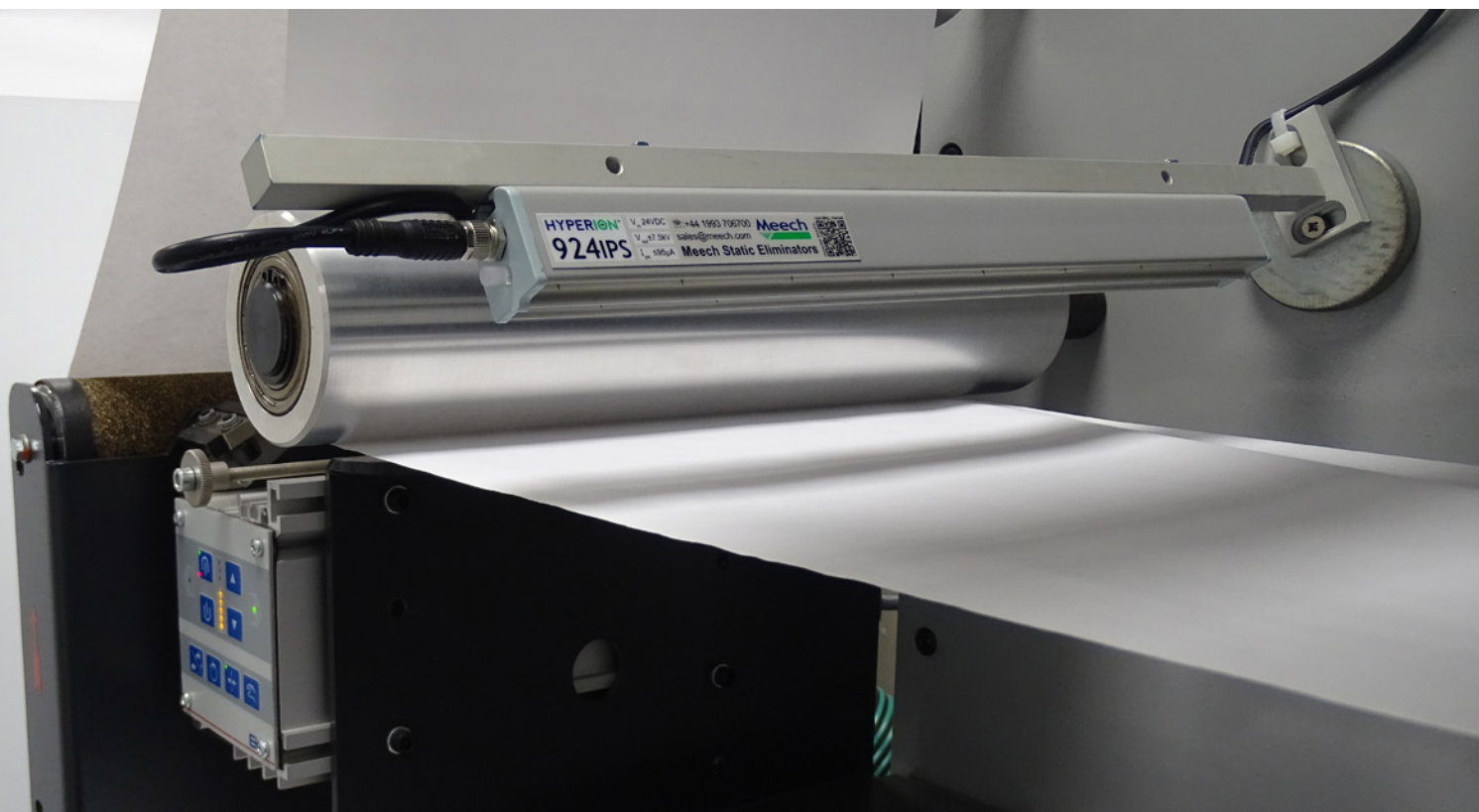

Features & Benefits

Optimum Working Distance

20-200mm; suitable for short range applications, such as web paths on converting machinery, printing presses or applications that have traditionally used AC equipment.

Compact Size & Full Length Ionisation

At just 22mm (W) x 32mm (H), it will fit into tight installations. The bar is also designed to give full performance over its entire length.

Low Voltage Wiring

Requiring a 24V DC supply removes the need for high voltage wiring to the ionising bar.

Integrated Power Supply (IPS)

The integral pulsed DC power supply uses surface-mount high voltage components. This reduces the overall size of the bar, making it the most compact 24V DC bar available.

Adjustable Output

Output voltage, frequency and balance can be adjusted using the BarMaster programmer. Adjustable output optimises the bar for sensitive applications like RFID.

Adjustable Clean Pin Alert

Meech Ion Current Monitoring (ICM) technology detects when the 924IPS needs to be cleaned. The LED on the bar alerts operators of the need for cleaning. This ensures peak performance is maintained.

Environmental Protection

IP66 construction makes the bar suitable for harsh environments.

Remote Signal

An output signal will activate when the bar needs cleaning or a fault has been detected. This will alert operators remotely to check the bar.

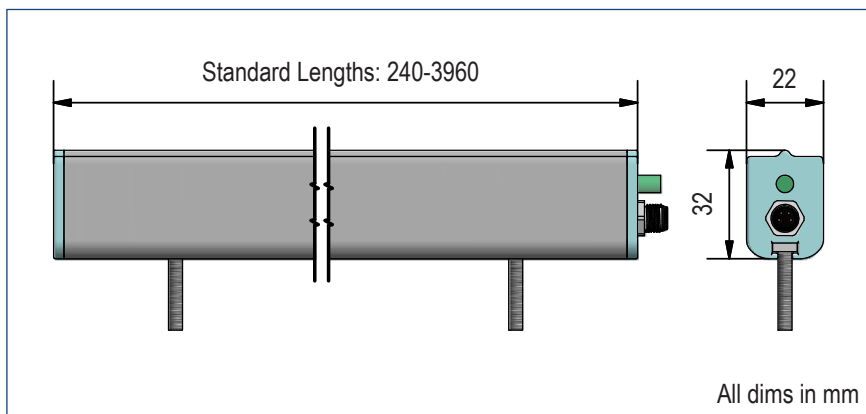

Technical Characteristics

Dimensions (WxH)
22mm x 32mm

Maximum Length
3960mm

Weight
0.5kg/metre

Construction
FR ABS

Input Current
Max 500mA

Input Voltage
24V DC (21-27V DC)

Output Voltage
Adjustable, +/- 4 to 7.5kV pulsed DC

Electrical Connection
4 pole M8

Output Frequency
Default Setting: 20Hz
Adjustable with BarMaster from 1Hz to 20Hz

Output Balance
Default Setting: 54% Positive, 46% Negative
Adjustable with BarMaster from 80:20 to 20:80 Pos:Neg

Environmental Protection
IP66

Mounting
'T' Slot with M4 x 20mm studs

Emitters
Sharp Titanium Pins

Max Ambient Temperature
60°C

Hyperion 929IPS

Medium Range DC Ionising Bar



The Hyperion 929IPS is a compact medium range pulsed DC ionising bar, powered by a 24V DC Integrated Power Supply (IPS).

With dimensions of just 26mm (W) x 43mm (H), the Hyperion 929IPS is easily installed onto printing and converting machinery. The class-leading +/-10kV pulsed DC output provides extremely powerful ionisation.

As with other Hyperion products, the 929IPS features Meech's Ion Current Monitoring (ICM) technology, which ensures performance is maintained with local and remote alerts when the bar needs cleaning.

Fully BarMaster compatible, the frequency and balance can be adjusted to optimise performance to suit particularly difficult applications.



Features & Benefits

Optimum Working Distance

100-500mm; suitable for mid range applications, such as reducing the static charge on blow moulded bottles or printing presses.

Low Voltage Wiring

Requiring a 24V DC supply removes the need for high voltage wiring to the ionising bar.

Integrated Power Supply (IPS)

The integral pulsed DC power supply uses surface-mount high voltage components. This reduces the overall size of the bar.

Adjustable Output

Frequency and balance can be adjusted with the BarMaster programmer.

Adjustable Clean Pin Alert

Meech Ion Current Monitoring (ICM) technology detects when the 929IPS needs to be cleaned. The LED on the bar alerts operators of the need for cleaning. This ensures peak performance is maintained.

Environmental Protection

IP66 construction makes the bar suitable for harsh environments.

Remote Signal

An output signal will activate when the bar needs cleaning or a fault has been detected. This will alert operators remotely to attend the bar.

Shockless Titanium Emitters

Virtually indestructible and safe to handle, will ensure many years' service.

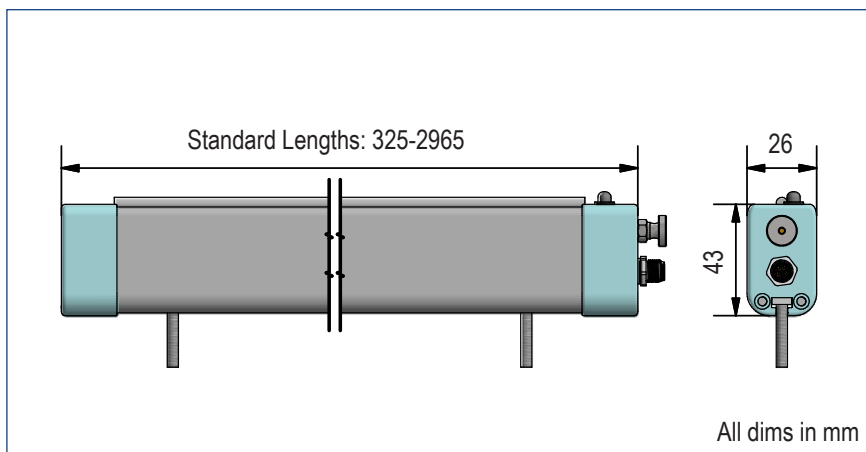

Technical Characteristics

Dimensions (WxH)

26mm x 43mm

Maximum Length

2965mm

Weight

0.9kg/metre

Construction

PVC/FR ABS

Input Current

Max 500mA

Input Voltage

24V DC (21-27V DC)

Output Voltage

+/- 10kV pulsed DC

Electrical Connection

4 pole M8

Output Frequency

Default setting: 5Hz

Adjustable with BarMaster from 1Hz to 20Hz

Output Balance

Default setting: 52% Positive, 48% Negative

Adjustable with BarMaster from 80:20 to

20:80 Pos:Neg

Environmental Protection

IP66

Mounting

'T' Slot with M4 x 20mm studs

Emitters

Sharp Titanium Pins

Max Ambient Temperature

60°C

Hyperion 971IPS

Long Range DC Ionising Bar



The Hyperion 971IPS is a long range pulsed DC ionising bar, powered by a +/- 15kV 24V DC Integrated Power Supply (IPS), which provides excellent long range ionisation. Designed to be easily installed, the 971IPS eliminates the need for high voltage cabling.

As with other Hyperion products, the 971IPS features Meech's Ion Current Monitoring (ICM) technology, which ensures performance is maintained with local and remote alerts when the bar needs cleaning.

Fully BarMaster compatible, the frequency and balance can be adjusted to optimise performance to suit applications requiring an operating distance of 300 to 900mm (1200mm with air boost).



Features & Benefits

Optimum Working Distance

300-900mm (1200mm with air boost); suitable for long range applications, such as slitter-rewinders, wicket bag machinery and turret winders.

Low Voltage Wiring

Requiring a 24V DC supply removes the need for high voltage wiring to the ionising bar.

Integrated Power Supply (IPS)

The integral pulsed DC power supply uses surface-mount high voltage components. This reduces the overall size of the bar.

Adjustable Output

Frequency and balance can be adjusted with the BarMaster programmer.

Air Boost

The range of the 971IPS can be increased to 1200mm by using the integral air boost via the 6mm push-fit air fitting.

Adjustable Clean Pin Alert

Meech Ion Current Monitoring (ICM) technology detects when the 971IPS needs to be cleaned. The LED on the bar alerts operators of the need for cleaning. This ensures peak performance is maintained.

Removable Titanium Emitters

The emitter pin assemblies are designed to be easy to clean and replace, allowing the 971IPS to maintain performance for many years.

Remote Signal

An output signal will activate when the bar needs cleaning or a fault has been detected. This will alert operators remotely to attend the bar.

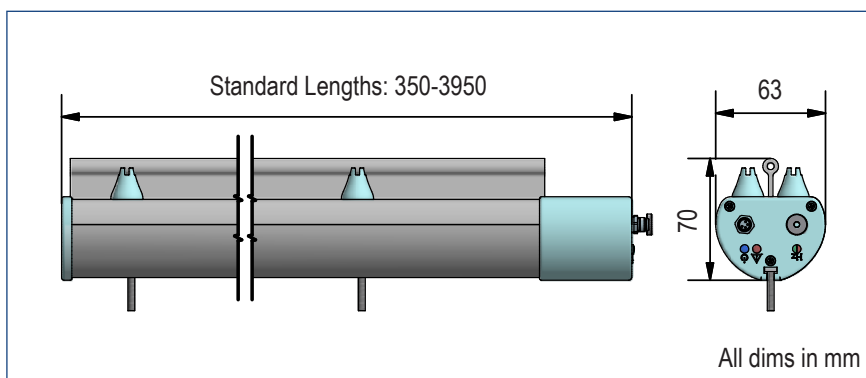

Technical Characteristics

Dimensions (WxH)

63mm x 70mm

Maximum Length

3950mm

Weight

1.2kg/metre

Construction

FR ABS

Input Current

Max 500mA

Input Voltage

24V DC (21-27V DC)

Output Voltage

+/- 15kV pulsed DC

Electrical Connection

4 pole M8

Output Frequency

Default setting: 1Hz

Adjustable with BarMaster from 1Hz to 20Hz

Output Balance

Default Setting: 60% Positive, 40% Negative

Adjustable with BarMaster from 80:20 to 20:80 Pos:Neg

Environmental Protection

IP64 as standard; IP65 upon request

Mounting

'T' Slot with M4 x 20mm studs

Emitters

Sharp Titanium Pins

Max Ambient Temperature

60°C

Air Boost Connection

6mm push-fit

Air Consumption

5cfm per 1000mm at 1 bar

Hyperion 959IPS

Ionising Air Curtain



The Hyperion 959IPS ionising air curtain is an extremely versatile product that provides effective static neutralisation and dust removal for a wide range of industrial applications.

The unit comprises a Hyperion 924IPS mounted on a Meech energy saving air curtain. Combined they provide a high speed laminar sheet of ionised air.

As with other Hyperion products, the 959IPS features Meech's Ion Current Monitoring (ICM) technology, which ensures performance is maintained with local and remote alerts when the bar needs cleaning.

Fully BarMaster compatible, the frequency and balance can be adjusted to optimise performance.

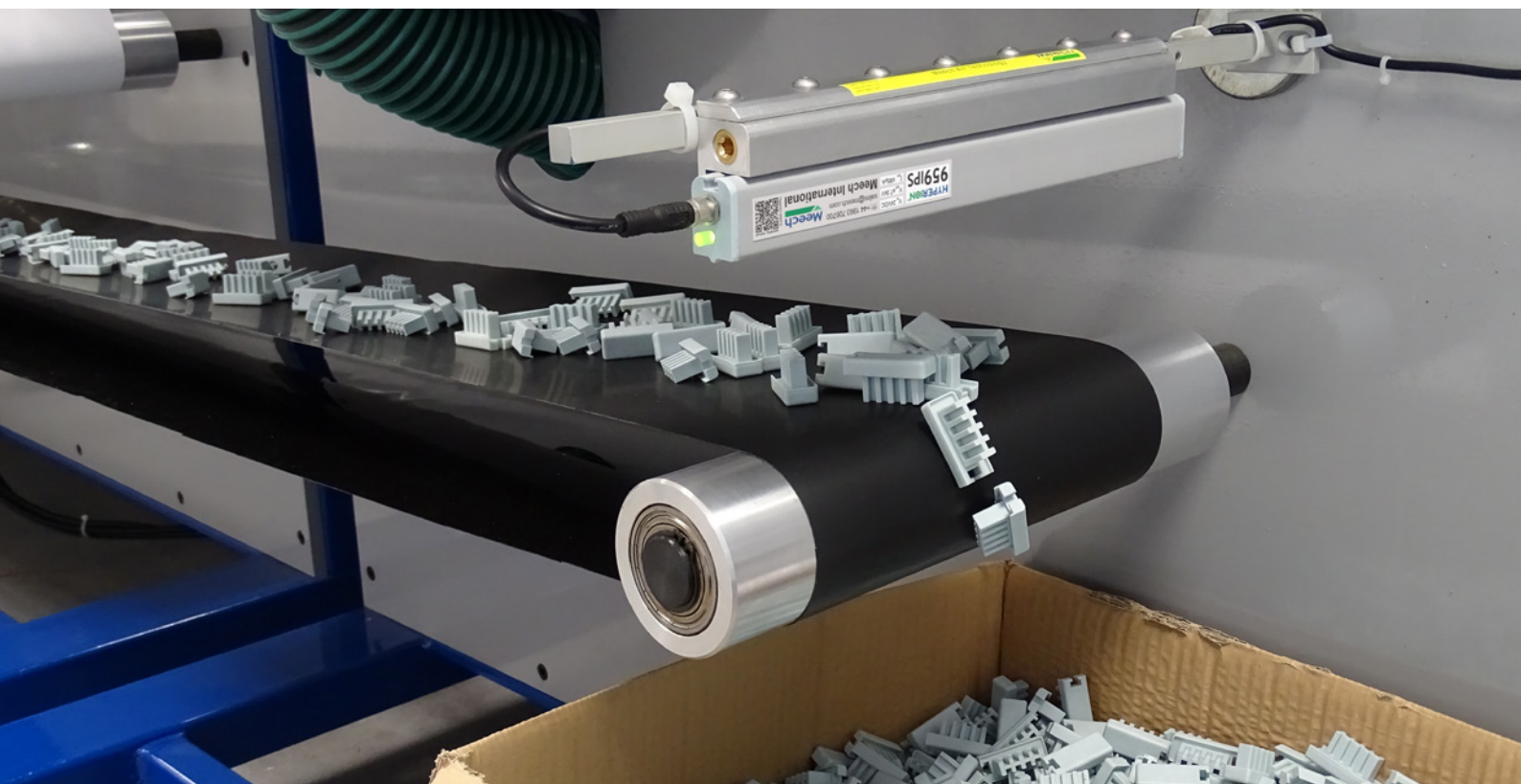

Features & Benefits

Optimum Working Distance

20-300mm for dust removal combined with a typical effective ionisation range of up to 300mm.

Energy Efficient Air Curtain

Can cut compressed air demand by up to 70%, reducing running costs.

Low Voltage Wiring

Requiring a 24V DC supply removes the need for high voltage wiring to the ionising bar.

Integrated Power Supply (IPS)

The integral pulsed DC power supply uses surface-mount high voltage components. This reduces the overall size of the bar.

Adjustable Output

Output voltage, frequency and balance can be adjusted using the BarMaster programmer. Adjustable output optimises the bar for a range of applications.

Adjustable Clean Pin Alert

Meech Ion Current Monitoring (ICM) technology detects when the 924IPS needs to be cleaned. The LED on the bar alerts operators of the need for cleaning. This ensures peak performance is maintained.

Environmental Protection

IP66 construction makes the ionising air curtain suitable for harsh environments.

Remote Signal

An output signal will activate when the bar needs cleaning or a fault has been detected. This will alert operators remotely to attend the bar.

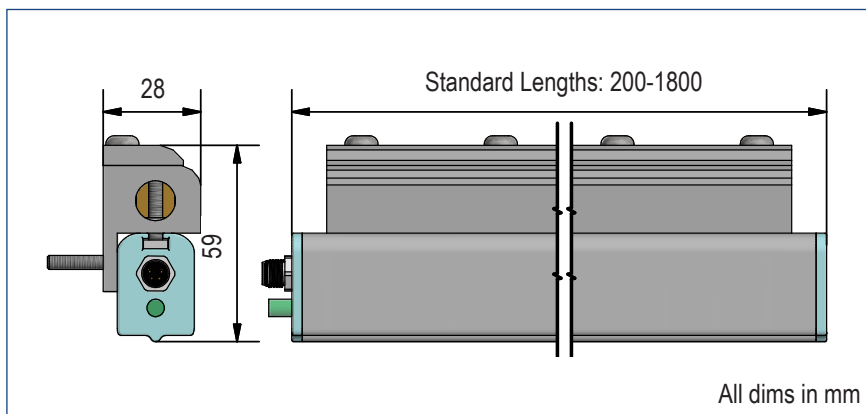

Technical Characteristics

Dimensions (WxH)

28mm x 59mm

Maximum Length

1800mm

Weight

2.1kg/metre

Construction

FR ABS / Aluminium

Input Current

Max 500mA

Input Voltage

24V DC (21-27V DC)

Output Voltage

Adjustable, 4 to 7.5kV pulsed DC

Electrical Connection

4 pole M8

Output Frequency

Default Setting: 20Hz

Adjustable with BarMaster from 1Hz to 20Hz

Output Balance

Default Setting: 54% Positive, 46% Negative

Adjustable with BarMaster from 80:20 to

20:80 Pos:Neg

Environmental Protection

IP66

Mounting

'T' Slot with M4 x 20mm studs

Emitters

Sharp Titanium Pins

Max Ambient Temperature

60°C

Air Curtain Connection

1/4" BSP

Air Consumption

112 l/min at 5 Bar per 25mm of length

Hyperion 906 and 907

Power Supplies for all non-Hyperion Bars



The Hyperion 906 and 907 produce a high voltage AC supply, required by AC ionisers, from the 24V DC supply found on most machinery. They produce an adjustable output of up to 7kV AC, making them suitable for a wide range of applications.

The Hyperion 906 and 907 can power any Meech AC ioniser, and each power unit will provide a high voltage connection for up to four ionisers. The 24V DC input voltage means they operate independently of local mains voltage and frequency; they are also significantly lighter and smaller than previous models.



Features & Benefits

24V Input Voltage

Universal supply voltage, found on modern machinery, Hyperion 906 and 907 can operate independently of local mains voltage and frequency.

Adjustable AC Output

Output voltage of between 4 and 7kV can be set (with BarMaster programmer). This means the Hyperion 906 and 907 can be set up to suit any Meech ioniser, making them truly universal.

Universal Meech HT Connection

Up to four standard Meech AC products can be connected to a single power unit, without any modification.

Twin Red/Green LED's

Easy to see LED indicators ensure the state of the power unit can be viewed at any angle. The colour and state of the LEDs, show whether the system is operating correctly or if it needs attention.

HT Failure Alert

Local and remote alert of damage or HT failure.

Clean Pin Alert (907)

Local and remote instruction to clean the bar. The LED will illuminate to indicate the system is on, working correctly and giving good ionisation performance. A change to a flashing red LED shows Meech's Ion Current Monitoring (ICM) technology has detected that the bars need cleaning.

Spark Detection (907)

The spark detection system will detect any problem as it happens and alert the operator by a fast flashing LED. The alert can also be monitored remotely via the alarm signal wire.

Balance Adjustment (907)

For critical electronic applications the offset voltage that is found on AC bars can potentially cause failures of integrated circuitry. The ability to remove this offset voltage with the 907 and deliver precise neutralisation means that AC bars can be used on applications that, previously, they were unsuitable for.

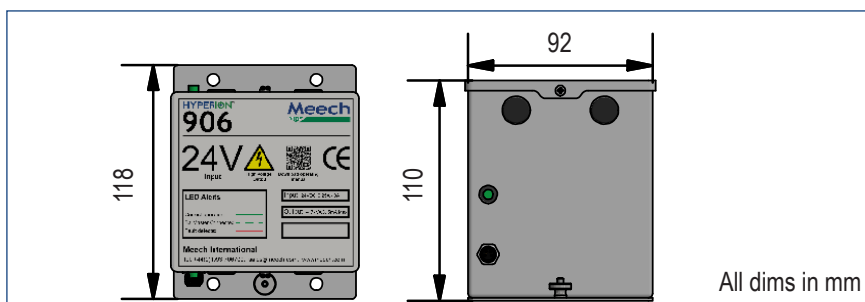

Technical Characteristics

Dimensions (WxHxD)

92mm x 110mm x 118mm

Weight

2.2kg

Construction

Painted Steel

Input Current

200mA-850mA Load Dependant

Input Voltage

24V DC - N.B. Supply must be grounded.

Output Voltage

Adjustable, 4 to 7kV AC

Output Frequency

67Hz

Connection

Murr 4 pin M8, Earth terminal

Settings Control

BarMaster

Output Signal

Open Collector Output Max 24V, 20mA

Local Indication

Twin Green/Red LEDs

Hyperion BarMaster

Remote Programmer



The Hyperion BarMaster is a remote programmer designed to connect with any Hyperion product.

The BarMaster temporarily connects inline with the 24V power supply to the bar and allows adjustment of the output and clean pin alert settings. When programming is completed the BarMaster is disconnected, once re-powered the Hyperion ionisers will operate at the programmed settings.



Features & Benefits

Universal

Hyperion BarMaster can be used to adjust the settings of any Hyperion product.

Hand Held Programmer

Portable and easy to carry around.

Frequency Adjustment

Frequency can be adjusted to suit different operating distances.

Balance Adjustment

Balance can be set for the most rapid static control in demanding applications or for the best balance on sensitive applications.

Clean Pin Alert

Clean pin alert setting can be changed to suit the demands of the application.

Future Proof

The BarMaster has been designed to be compatible with current and future Hyperion products.

Technical Characteristics

Dimensions (WxHxD)

81mm x 143mm x 25mm

Construction

ABS

Cable Length

2000mm

Input Voltage

24V

Electrical Connection

4 pin M8 Connector

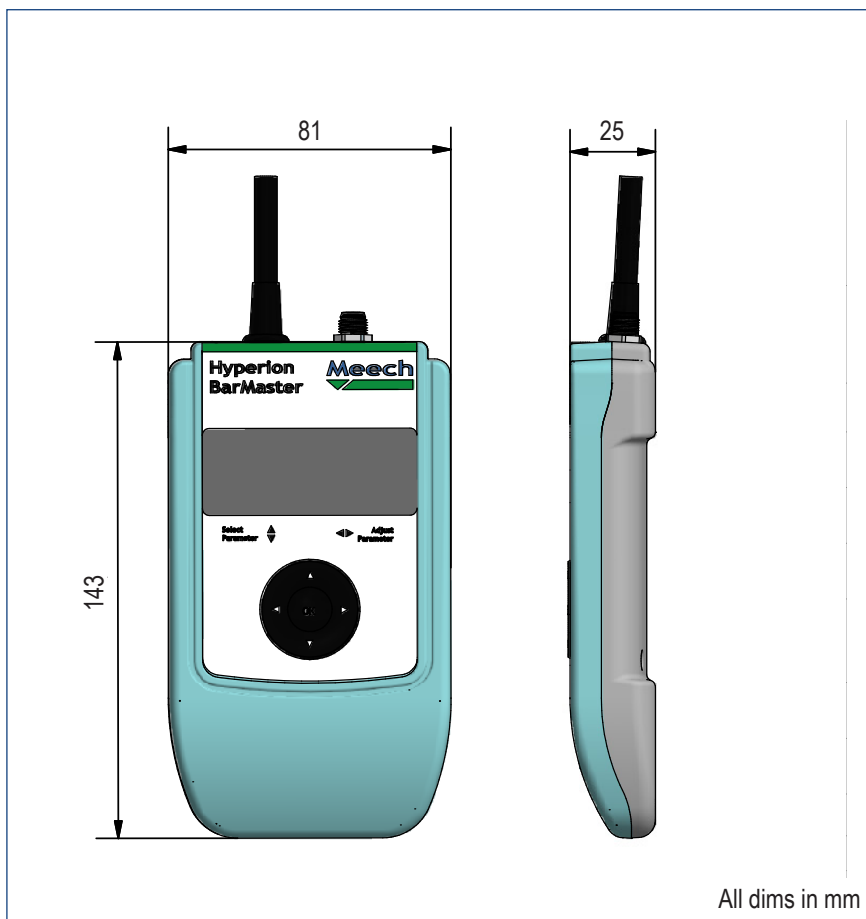

Hyperion Feedback Sensor

for Hyperion 929IPS and 971IPS



Our closed-loop feedback system takes advantage of the adjustable balance of pulsed DC ionising systems.

The system comprises a Hyperion 929IPS or 971IPS bar which has been feedback enabled. Connected to the bar is an external, high accuracy, voltage sensor that measures the voltage on the web downstream of the ionising bar.

This measurement is fed back to the bar which automatically adjusts the balance of the output to achieve a completely neutral web. This is a continuous process that constantly measures and adjusts to achieve the very best static control at all times.

Features & Benefits

Feedback for Mid and Long Range Bars

Option for Hyperion 929IPS and 971IPS bars

Third Party High Accuracy Sensor

Recognised and trusted brand for measurement instrumentation

M8 Connection

Simple and quick connection

Analogue Output

Allows data logging and monitoring

Technical Characteristics

Measuring Range

+/-20kV

Output

1-5V DC (Output impedance Approx. 100ohms)

Linearity

+/- 5%F.S.

Installation Distance

50mm

Cable Length

5000mm

Weight

185g

Ambient Humidity

35% to 85% RH

Hyperion Distance Sensor

for Hyperion 971IPS



Our Distance Sensor fits to any feedback enabled 971IPS bar and is designed to automatically adjust the output frequency to match the target distance, decreasing the frequency if the target is far away and increasing it when the target is closer.

The Hyperion 971IPS bar offers excellent static control over a wide range of distances. Its default frequency of 1Hz is suitable for the majority of applications and is especially effective at long range.

However, when working at close ranges increasing the frequency of the output will give improved results. Adjustment can be made using a BarMaster programmer but this doesn't offer the best solution when the distance to the target changes during operation.

The Hyperion Distance Sensor is designed to work when the distance to the target is constantly changing, allowing the performance of the 971IPS to be optimised.

Features & Benefits

Control of Mid and Long Range Bars

Option for any feedback enabled Hyperion 971IPS Pulsed DC Bar

Ultrasonic Distance Sensor

Clear distance measurement

Auto-detection of Sensor

No set-up of the integrated controller is required

Technical Characteristics

Dimensions (WxHxD)

75mm x 88mm x 65mm

Construction

ABS

Cable Length

Coiled 3000mm

Electrical Connection

3 pin M8 Connector

Weight

83g

Ambient Temperature

0 to 50 °C

All you need, from the best in the business

Meech is also a leading provider of:

Web Cleaning Systems – Typically used within the printing and packaging industries to remove contamination, improve print quality and increase productivity.

JetStream Air Knife Systems – Energy efficient air knife systems that are used for contamination and surface moisture removal.

Air Technology Equipment – Compressed air products that save energy, reduce noise levels and provide efficient cooling.

IonRinse™ – Energy efficient ionising air rinsing system for the beverage, food and pharmaceutical processes.



Meech International
2 Network Point
Range Road, Witney
OX29 0YN, UK

Tel: +44 (0)1993 706700
Fax: +44 (0)1993 776977
email: sales@meech.com

Meech Static Eliminators USA Inc
2915 Newpark Drive
Norton, OH 44203
USA

Tel: +1 330 564 2000 /
1 800 232 4210
Fax: +1 330 564 2005
email: info@meech.com

Meech Elektrostatik SA
Kaiserbaracke 66
B-4780 St.Vith
Belgium

Tel: +32 80 670 204
Fax: +32 80 862 821
email: mesa@meech.com

Meech CE
2151 Fót
Széchenyi út. 46
Hungary

Tel: +36 27535075
Fax: +36 27535076
email: ce@meech.com

Meech Shavotech
Shavo House, Survey No.21A /
10 B, Plot No.394
South Main Road, Koregaon Park,
PUNE 411 001
India

Tel: 020-26159641/ 26159642,
Fax: 020-26159644
e-mail: india@meech.com

Meech Static Eliminators
(Shanghai) Co. Ltd
7G, 7F, LP Tower
#25 Xiangfeng Road
201103 Shanghai
China

Tel: +86 400 820 0102
Fax: +86 21 6405 7736
email: china@meech.com